

(No Model.)

2 Sheets—Sheet 1.

R. R. SPEARS.  
TURNING LATHE FOR AXLE BOXES.

No. 530,861.

Patented Dec. 11, 1894.

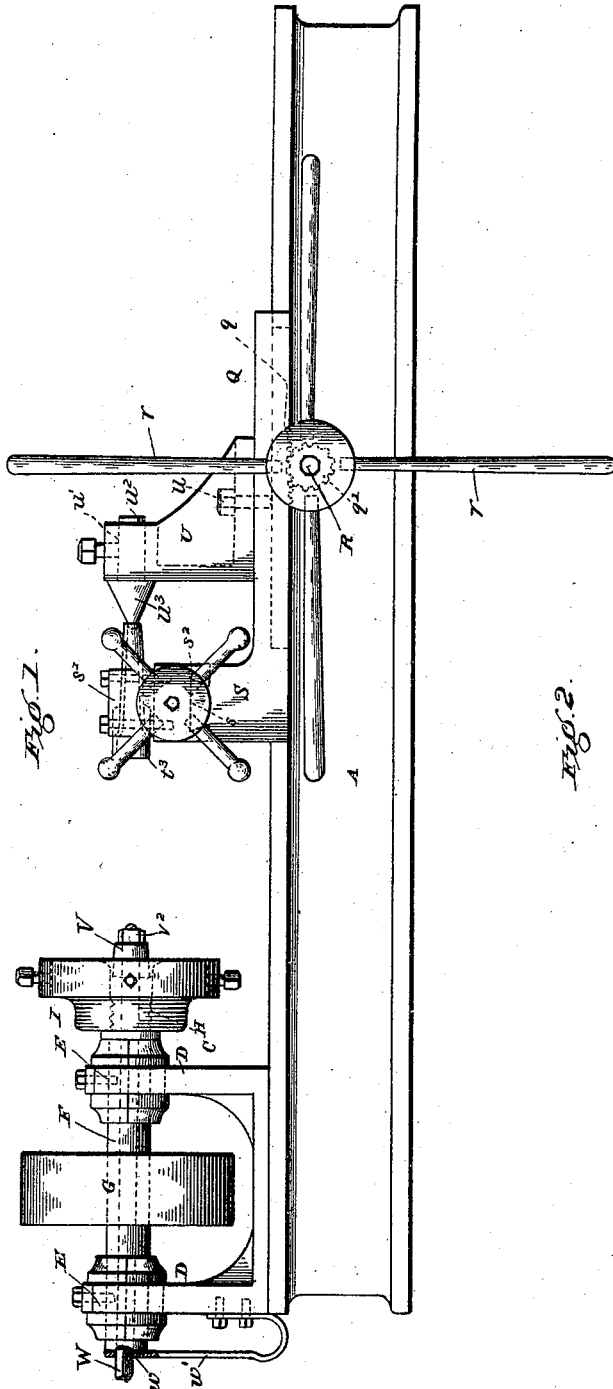

Fig. 1.

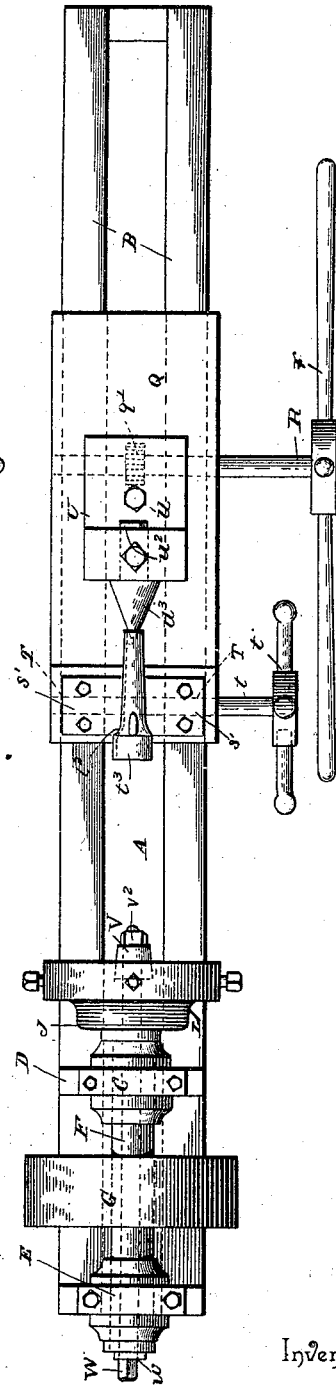

Fig. 2.

Inventor

Ralph R. Spears

By his Attorneys.

C. Snow & Co.

Witnesses  
W. Johnson  
D. C. Schaeffer

(No Model.)

2 Sheets—Sheet 2.

R. R. SPEARS.  
TURNING LATHE FOR AXLE BOXES.

No. 530,861.

Patented Dec. 11, 1894.

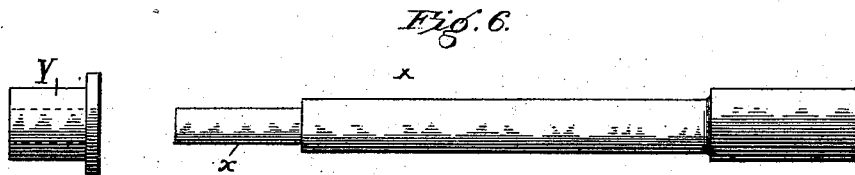
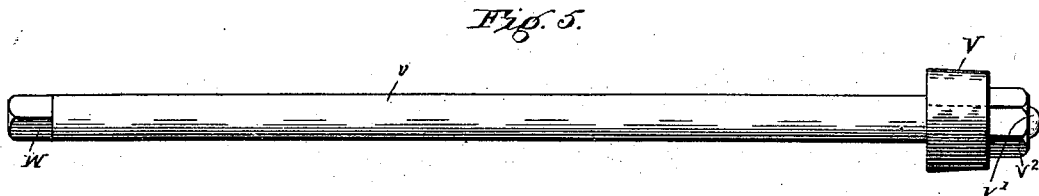
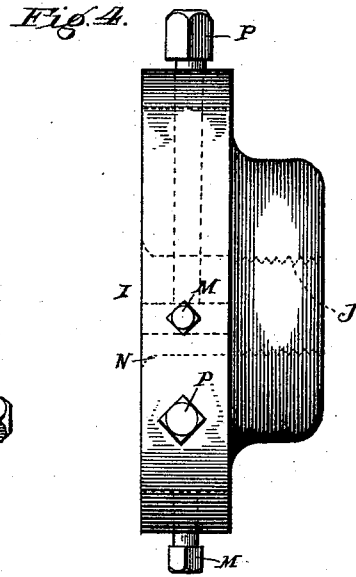
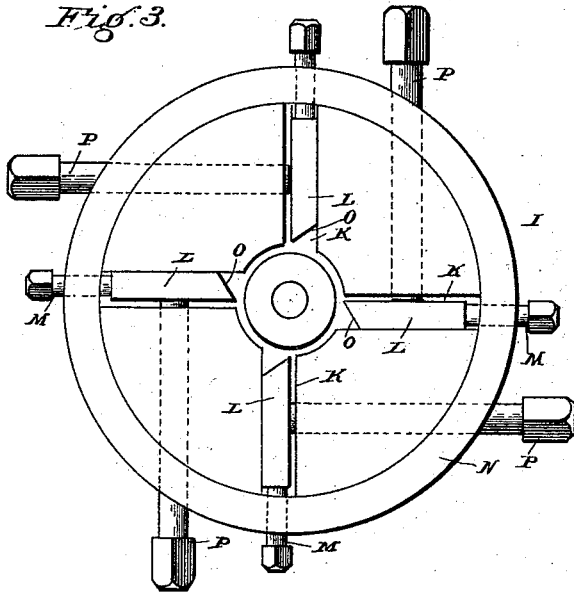

Inventor

*Ralph R. Spears*

By his Attorneys,

*C. Snow & Co.*

Witnesses

*Ed Johnson*  
*D. P. Walker*

# UNITED STATES PATENT OFFICE.

RALPH REED SPEARS, OF WHEELING, WEST VIRGINIA.

## TURNING-LATHE FOR AXLE-BOXES.

SPECIFICATION forming part of Letters Patent No. 530,861, dated December 11, 1894.

Application filed November 10, 1893. Serial No. 490,577. (No model)

*To all whom it may concern:*

Be it known that I, RALPH REED SPEARS, a citizen of the United States, residing at Wheeling, in the county of Ohio and State of West Virginia, have invented a new and useful Turning-Lathe for Axle-Boxes, of which the following is a specification.

This invention relates to turning lathes for axle boxes; and it has for its object to provide a machine of this character which shall provide simple and efficient means for accurately turning the exterior periphery of ordinary carriage and wagon axle boxes.

To this end the invention consists in the novel construction, combination and arrangement of parts hereinafter more fully described, illustrated and claimed.

In the accompanying drawings:—Figure 1 is a side elevation of an axle box turning lathe constructed in accordance with this invention; showing the lathe set for operating upon the large end of the axle box. Fig. 2 is a top plan view of the construction shown in Fig. 1. Fig. 3 is a front view of the cutter head. Fig. 4 is a projected side view of the same. Fig. 5 is a detail elevation of the stationary mandrel employed when the large end of the axle box is being turned. Fig. 6 is a similar view of the form-mandrel and the guide bush used in connection therewith when turning the axle box from the small end thereof.

Referring to the accompanying drawings, A represents a lathe bed supported on legs or standards in the usual manner and provided on the top thereof with the parallel guides or ways B, extending the entire length thereof. On one end and the top of the lathe bed A, is mounted the head stock C, having the parallel upright bearing arms D, which terminate at their upper extremities in the bearing boxes E, which form bearings for the hollow live spindle F.

The hollow live spindle F, which is mounted for rotation in the bearings E, is hollow throughout the entire length and carries at a point between the bearing arms of the head stock a drive pulley G, which receives a suitable belt designed to impart motion to the said live spindle and the cutting devices carried thereby. The hollow live spindle F, is provided with an inner exteriorly threaded end

H, which is adapted to removably receive the rotary cutter head I.

The rotary cutter heads I, are constructed in widths depending upon the length of axle boxes being turned, and as clearly shown in the drawings each of such cutter heads I, is provided with an interiorly threaded opening J, which engages the threads of the exteriorly threaded end of the hollow spindle, so that the cutter head will be rotated by such spindle. The cutter head I, is provided with a series of radial slots K, which accommodate the adjustable cutter bits L, fitting therein. The several cutter bits L, are adapted to be adjusted according to the size of the axle box being operated upon, and such adjustment is secured by means of the adjusting screws M, mounted in the retaining band or ring, N, which exteriorly encircles the cutter head, and working into the outer ends of the slots K, against the outer ends of the cutter bits, which are provided with inner beveled cutting edges O. The cutter bits L, are held fast in any adjusted position by means of the long binding screw P, also passing through the retaining band or ring N, and the body of the head I, so as to enter the slots K, at one side of the cutter bits therein.

The work is moved onto the revolving cutter head I, by the sliding feed carriage Q. The sliding feed carriage Q, is mounted to slide on the parallel guides or ways B, of the lathe bed, and is provided on the bottom thereof with the feed rack *q*, adapted to be engaged by the feed pinion *q'*, mounted on the feed shaft R, journaled transversely in the top portion of the lathe bed, and carrying at one end a feed wheel *r*, by means of which the carriage can be moved to and away from the cutter head. The said sliding feed carriage Q, is provided at its inner end facing the cutter head with an integral upwardly extending vise block S, having on the top face thereof a transverse dove-tail tongue, which adjustably receives the oppositely moving vise jaws *s'*, provided with the bottom dove-tail grooves *s''*, which embrace the projecting tongue of the vise block and thereby connect the jaws by a sliding connection or joint with such vise block.

The oppositely moving vise jaws *s'*, which

are mounted to slide on top of the vise block  
s, are provided with reversely threaded open-  
ings T, which are adapted to receive the right  
and left screw threaded adjusting screw *t*,  
5 carrying at one end a hand wheel *t'*, and pro-  
viding means for moving the vise jaws to and  
away from each other. The said vise jaws  
are provided with inner adjacent circularly  
flared and tapered vise faces, which, together,  
10 correspond to the exterior shape of an ordi-  
nary axle box *t*<sup>2</sup>, which is designed to be  
clamped therebetween, and as is clearly illus-  
trated in Figs. 1 and 2 of the drawings, said  
axle box is shown as clamped in position be-  
15 tween the vise jaws registering therewith,  
and presenting the large collar end thereof  
for the cutter head to operate upon.

Immediately in rear or at one side of the  
vise block at the inner end of the feed car-  
riage is adjustably mounted the post block  
U. The post block U, is adjustably clamped  
on top of the feed carriage by means of the  
securing screws *u*, passing through its base  
and engaging any one of the series of threaded  
25 openings in the feed carriage. The post block  
U, is provided at its upper end with a cylin-  
drical opening *u'*, which removably receives  
the round shank *w*<sup>2</sup>, of the conical central  
post *w*<sup>3</sup>, the pointed end of which is adapted  
30 to fit in the small end of the axle box, when  
clamped in the position shown in Figs. 1 and  
2 of the drawings, so as to hold and center  
the axle box which is prevented from turn-  
ing between the vise jaws by the lugs or  
35 flanges at the large end thereof. The post  
block U, is adjusted to and away from the  
vise according to the length of the axle box  
being operated upon.

Assuming the axle box to be in the position  
40 shown in Figs. 1 and 2, the feed carriage is  
now moved up to the rotary cutter head until  
the large end of the axle box is carried into  
the center opening of the cutter head, sur-  
rounded by the cutting edges of the radial  
45 cutter bits, and arranged in this central open-  
ing of the cutter head is the cylindrical  
guide collar V, which is slightly tapered so  
as to snugly receive and fit inside of the large  
end of the axle box when being operated upon.  
50 This guide collar V, is clamped on one end  
of the longitudinally movable mandrel *v*,  
which is arranged inside of the hollow spin-  
dle F, and is provided at one end with the re-  
duced portion *v'*, to receive the collar V, and  
55 the nut *v*<sup>2</sup>, binding the same thereon, while  
the other end of the mandrel projecting be-  
yond the outer end of the hollow spindle is  
squared, as at W, to receive the squared open-  
ing *w*, at the upper end of the spring *w'*, se-  
60 cured to one end of the head stock. As soon  
as the large end of the axle box has been  
forced tight onto the guide collar V, the man-  
drel *v*, will be moved outward against the  
tension of the spring *w'*, so as to keep the  
65 guide collar inside of one end of the axle box  
while the cutter head is operating on such  
axle box, and when the feed carriage is moved

away from the cutter head, the mandrel will  
be moved, under the tension of the spring, so  
as to force the axle box back with the feed  
70 carriage and out of the cutter.

When the small end of the axle box is to  
be operated on up to the lugs or flanges near-  
est the large end, the stationary mandrel and  
its attachments are removed from the hollow  
75 spindle, as well as the conical center post *w*<sup>3</sup>,  
and in place of this center post a form-man-  
drel X, is employed. The form mandrel X,  
is of a shape which registers snugly with the  
interior of the axle box, which together with  
80 such mandrel can be properly clamped in the  
vise to present the proper end of the axle box,  
and the said form-mandrel is provided at the  
reduced end thereof with the projecting guide  
tongue *x*, which is adapted to slide in the  
85 cylindrical guide bush Y, fitted in the inner  
threaded end of the hollow spindle, after the  
stationary mandrel has been removed. The  
operation of cutting the tapered portion of  
the axle box is substantially as just described  
90 for the other end, and will be clear to those  
skilled in the art.

Changes in the form, proportion and the  
minor details of construction may be resorted  
to without departing from the principle or  
95 sacrificing any of the advantages of this in-  
vention.

Having thus described the invention, what  
is claimed and desired to be secured by Let-  
ters Patent, is— 100

1. In a turning lathe for axle boxes, the  
combination of the live spindle mounted fix-  
edly at one end, a cutter head mounted on  
one end of said spindle and having a central  
opening, a self-adjusting spring-projected  
105 work guide arranged to move within the cen-  
tral opening of the cutter head and adapted  
to be normally projected out of said central  
opening beyond the cutter head, and a slid-  
ing feed carriage adapted to be moved to  
110 and from the cutter head, substantially as set  
forth.

2. In a turning lathe for axle boxes, the  
combination with the lathe bed; of a hollow  
spindle mounted at one end of the bed, a ro-  
tary cutter head mounted on the inner end  
115 of said spindle and having a central opening,  
a cylindrical guide bush adapted to be fitted  
in the inner end of the hollow spindle in a  
line with the central opening of the cutter  
head, a work vise adapted to be moved to  
120 and from the cutter head, and a form-man-  
drel of an exterior shape corresponding to the  
interior shape of an axle box and provided  
at one end with a guide tongue adapted to  
125 work in said guide bush, substantially as set  
forth.

3. In a turning lathe of the class described,  
the combination of the lathe bed having a  
head stock at one end, a live spindle jour-  
naled on the head stock, a rotary cutter head  
130 mounted on the inner end of the live spindle,  
a sliding feed carriage mounted on the lathe  
bed, and provided at one end with an up-

wardly extended vise-block, simultaneously adjustable vise jaws mounted on said block, a post block adjustably secured directly on top of the carriage at one side of the vise-block thereof, a conical work holding center post having a shank removably mounted in the upper end of said post block, and a rack and pinion device for moving the feed carriage in either direction, substantially as set forth.

4. In a lathe of the class described, the combination of the lathe bed having a bearing head block at one end, a hollow live spindle journaled on said head block and threaded at its inner end, an interiorly threaded rotary cutter head removably mounted on the threaded end of the spindle and having a series of radial slots, cutter bits loosely arranged in said slots, a separate and independent retaining band or ring encircling the cutter head, adjusting screws mounted in said ring or band and working against the outer ends of the cutter bits to adjust the same, binding screws working in the cutter head and against one side of the cutter bit to hold

the same stationary in an adjusted position, and the sliding feed carriage, substantially as set forth.

5. In a lathe for turning axle boxes, the combination of the lathe bed, a hollow live spindle journaled in bearings at one end of the lathe bed, a rotary cutter head mounted on the inner end of the hollow spindle, a stationary mandrel arranged within said hollow spindle and projecting beyond both ends thereof, a stationary spring connected to the outer projecting end of said mandrel, a cylindrical and slightly tapered guide collar mounted on the inner end of the mandrel and working in the central opening of the cutter head, the sliding feed carriage, and the work holding center post mounted on said feed carriage, substantially as set forth.

In testimony that I claim the foregoing as my own I have hereto affixed my signature in the presence of two witnesses.

RALPH REED SPEARS.

Witnesses:

THEO. SCHULTZE,  
WM. G. PRICHARD.